

Calculator T550 (UC50...)

Residential, district heating, local heating plant

ULTRAHEAT[®]T550 (UC50...) ULTRACOLD[®]T550 (UC50...)



Technical description

32 19 101 001 a

Datum: 05.05.2015

Landis+Gyr GmbH

Outstanding features

- Also operable as combined heat / cooling meter calculator
 - Mounting place of flow sensor: hot or cold side possible
 - Big range of communication modules for remote readout and system integration
 - 2 module slots for using 2 communication modules coincidental
 - Optical interface according to EN 62056-21:2003
 - Power measurement with maximum values, tariffs selectable
 - Data logger for system monitoring
 - 60 monthly values
 - Logbook
 - Battery or mains operated
 - Self-diagnostics
 - Available for order as cooling meter calculator with German national approval
 - Available for order with one-time adjustable pulse value and mounting place of the flow sensor
 - Available for order for liquid mixtures (e. g. glycol / water)
-

Contents

1	General notes	5
	Other available documentations	5
2	Safety Information	6
3	Technical Data	7
4	Installation	8
	Examples of installation	8
4.1	Temperature sensors	9
4.2	Connection of flow sensor	10
5	Dimension of electronic unit	11
6	Operating elements	12
6.1	LCD	13
	Display values "LOOPS"	13
	User loop "LOOP 0"	13
	Service loop 1 "LOOP 1"	14
	Service loop 2 "LOOP 2"	15
	Service loop 3 "LOOP 3"	15
	Service loop 4 "LOOP 4"	16
6.2	Previous year's values	17
6.3	Monthly values	17
7	Parameterisation of pulse value and mounting place of flow sensor	17
8	Display / priority rating	18
9	Power supply	18
	Automatic power supply detection	18
	Power supply requirements	19
	Power supply modules	19
10	Communication	20
	Electronic unit interfaces	20
	Permissible combinations of modules	21
	Terminals	22
10.1	Pulse module	22
10.2	M-Bus module G4	23
10.3	M-Bus module MI with 2 pulse inputs	23
10.4	Analog module	24
10.5	Radio module 868 MHz (wireless M-Bus)	25
10.6	GSM module	26
10.7	GPRS module	27
10.8	ZigBee module	28
11	Tariff control (optional)	29
	Threshold value tariff (Tariffs T2, T3, T4, T5, T6)	29
	Supplied quantity of energy (tariff T7)	29
	Returned quantity of energy (tariff T8)	29
	Heat / cooling meter (tariff T9)	30
	Tariff control via timer switch (tariff T10)	30

	Tariff control via M-Bus (tariff T11) _____	30
	Surcharge quantity tariff by means of return temperature (tariff T12) _____	30
	Display of the tariff situation on the LCD _____	30
12	Error messages _____	32
13	Log functions _____	33
14	Data logger (optional) _____	34
15	Additional options _____	35
16	Order codes (type number key) _____	36
17	Additional ordering information on radio module 868 MHz (wireless M-Bus) _____	38
18	Additional ordering information for glycol _____	39

1 General notes



Note: In the following text, the term calculator refers to both heat meter calculator and cooling meter calculator, unless they are otherwise differentiated.

The calculator is used as a calculator for heating or cooling consumption measurement in systems with water.

The calculator forms the volume from the pulses of the flow sensor. The temperatures of the hot and cold sides are determined using platinum resistors. The volume of water and the temperature difference between hot and cold side are then calculated and the product is summated.

The result is that the quantity of thermal energy consumed is displayed in the units kWh / MWh or MJ / GJ.

Other available documentations

- Operating instructions T550 (UC50...)
- Installation instructions T550 (UC50...)
- Respective module operating and installation instruction
- Illustrated catalogue

Additional information's are available on request.

2 Safety Information



The calculator may only be used in building service engineering systems and only for the applications described.



The local regulations (installation etc.) must be adhered to.



Adhere to the operating conditions according to the dial plate during use. Non-adherence can cause hazards and the guarantee will lapse.



Guarantee and calibration validity will lapse if the calibration relevant security seals are broken.



Only clean the calculator from outside with a soft, lightly wetted cloth. Do not use any spirit or cleaning solvent.



The 110 V / 230 V connections may only be made by an electrician.



The calculator may only be powered up once the installation has been completed. There is otherwise a danger of electronic shock on the terminals.

A defective or obviously damaged appliance must be disconnected from the power supply immediately and replaced.



As far as disposal is concerned, the calculator is a waste electronic appliance in the sense of European Directive 2012/19/EU (WEEE) and it must not be disposed of as domestic waste.

- Dispose of the meter through the channels provided for this purpose.
- Respect the local and currently valid legislation.
- Dispose of used batteries at the collection points provided for them.



The calculator may contain lithium batteries. Do not dispose of the calculator and the batteries with domestic waste. Observe the local stipulations and laws on disposal.



You can return the lithium batteries to the manufacturer for appropriate disposal following use. When shipping please observe legal regulations, in particular, those governing the labelling and packaging of hazardous goods.



Do not open the batteries. Do not bring batteries into contact with water or expose to temperatures above 80 °C.



The calculator does not have any lightning protection. Ensure lightning protection via the in-house installation.



Only fit one compartment for the power supply. Do not remove the red locking hatch.

3 Technical Data

General

Environment class	A (EN 1434) for indoor installation
Mechanical class	M1 *)
Electromagnetic class	E1 *)
*) according to 2004/22/EC Directive on Measuring Instruments	
Ambient humidity	<93 % rel. humidity at 25 °C, without condensation
Max. height	2000 m above sea level
Storage temperature	-20 ... 60 °C

Electronic unit

Ambient temperature	5 ... 55 °C
Housing protection rating	IP 54 according to EN 60529
Safety class	
Line 110 / 230 V AC	II according to EN 61558
Line 24 V AC/DC	III according to EN 61558
Operation threshold f. ΔT	0.2 K
Temperature difference ΔT	3 K ... 120 K
Temperature measurement range	0 ... 180 °C
LCD	7 digit
Optical interface	Standard, EN 62056-21
Communication	Optional, e.g. M-Bus
Separability	Always, optional cable length
Battery	3.6 V DC Lithium
Power supply	230 / 110 V AC 50 / 60 Hz 24 V AC / DC 50 / 60 Hz
Power input	<0.8 W

Temperature sensor

Type	Pt 500 or Pt 100 according to EN 60751
------	--

Pulse input

Pulse input	IB / IC according to EN1434
Pulse length	min. 10 ms
Pulse frequency	max. 50 Hz
Pulse wire length	max. 20 m (recommended)

4 Installation



Note: The **mounting place** and the **pulse value** of flow sensors with pulse output must correspond to the in the calculator set values (see LOOP 2).

Service loop 2 “LOOP 2“

Service loop 2 displays the installation details.

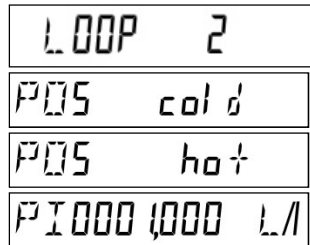

- Head of the loop
- Mounting place of the flow sensor: cold side or
- Mounting place of the flow sensor: hot side
- Pulse value



Note: At a **heat meter calculator** or combined heat / cold meter calculator the mounting place of the flow sensor cold side is equivalent to return. The mounting place of the flow sensor hot side is equivalent to flow.



Note: At a **cooling meter calculator** the mounting place of the flow sensor hot side is equivalent to the return. The mounting place of the flow sensor cold side is equivalent to flow.



Attention: Calculators with one-time adjustable pulse value and adaptable mounting place being characterized by:



Attention: At calculators with one-time adjustable pulse value, the pulse value must be adjusted during commissioning in accordance with the flow sensor and the mounting place must be checked!

As long as the pulse value has not been set, the calculator does not cumulated energy and volume.

The mounting place can be adapted and is fully locked by entering the pulse value.

Examples of installation

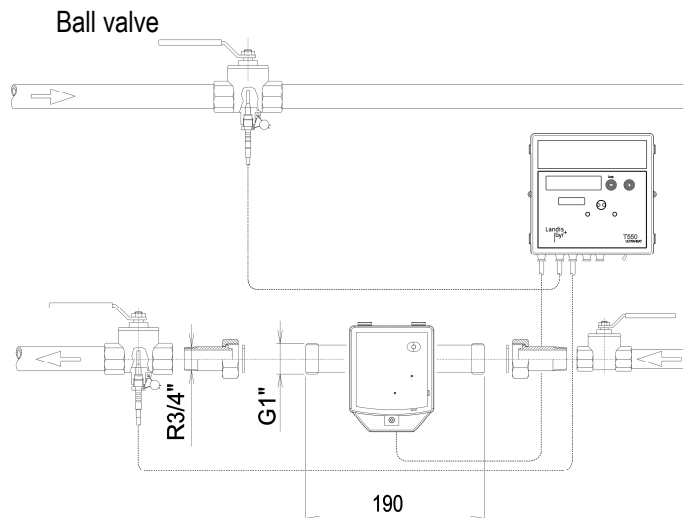

Fig. 1: Installation with a ball valve (recommended up to and including DN25)

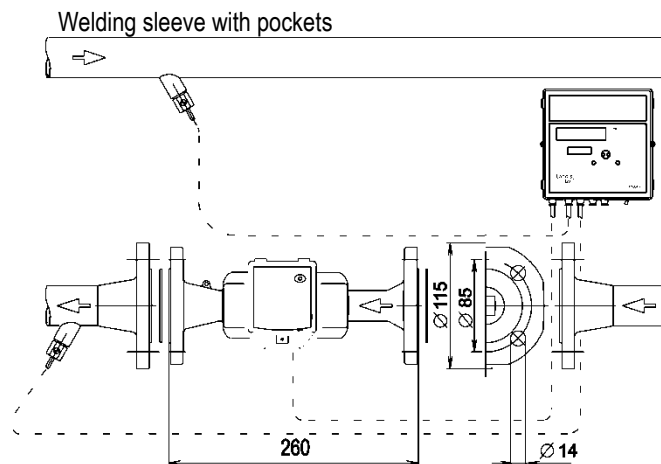

Fig. 2: Installation with pockets (recommended greater than or equal to DN32)

4.1 Temperature sensors



Note: The temperature sensor type PT 100 / 500 must correspond to the information on the dial plate.



Note: If detachable temperature sensors are used they must have their own calibration or certification of conformity!



Note: The maximum cable length of the temperature sensors is 10 m. Extension is not permitted.

- Press the 4 side lugs of the housing cover inwards and remove the cover.
- Guide the wire of the temperature sensor from the outside through the 2nd sleeve from the left and the return sensor through the 3rd sleeve from the left.
- Strip both wires as in the figure 3.

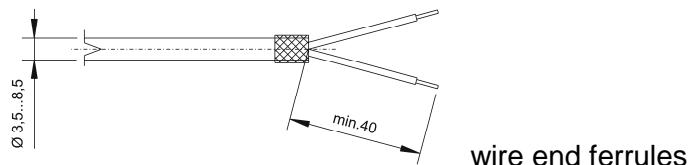

Fig. 3

- Connect the cores in line with the inscription printed on the meter. The 2-wire connection occurs on terminal 5/6 and 7/8. This also applies to a connection of 2-wire temperature sensors on a 4-wire connection terminal.



Note: Do not connect the shielding braid on the calculator side.

- Insert the temperature sensors into the pockets, ball-valves or T-pieces. The end of the temperature sensors must reach at least to the centre of the pipe cross-section.
- Seal the temperature sensors to protect against manipulation.
- Put the housing cover in position and press it gently until all the lugs click into place audibly.

4.2 Connection of flow sensor



Note: The flow sensor must be installed at the same circuit as the temperature sensors.



Note: When a polarity dependent pulse transmitter is used, take care of the correct orientation.

- Connect the negative reference potential (-) or GND on the right spring-type terminal.
- Connect the positive reference potential (+) on the left spring-type terminal.
- If the line has a shielding braid, push the shielding braid covering over the counter covering of the cable.
- For stain relief, fix the line on the outer sheath by a clamp.



Note: The shielding braid must not be connected to T550 (UC50...) when the flow sensor has its own ground connection.



Note: The cage clamp terminals can be used for cable cross-section of 0.5 ... 1.5 mm² (solid or stranded). In order to preserve the IP protection class of the housing, the outside diameter of the cable sheath shall be 3.7 ... 4.4 mm.

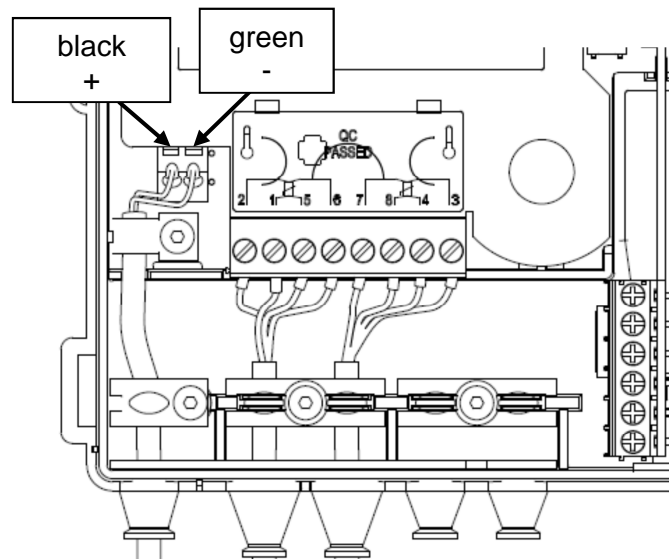

Fig. 4

5 Dimension of electronic unit

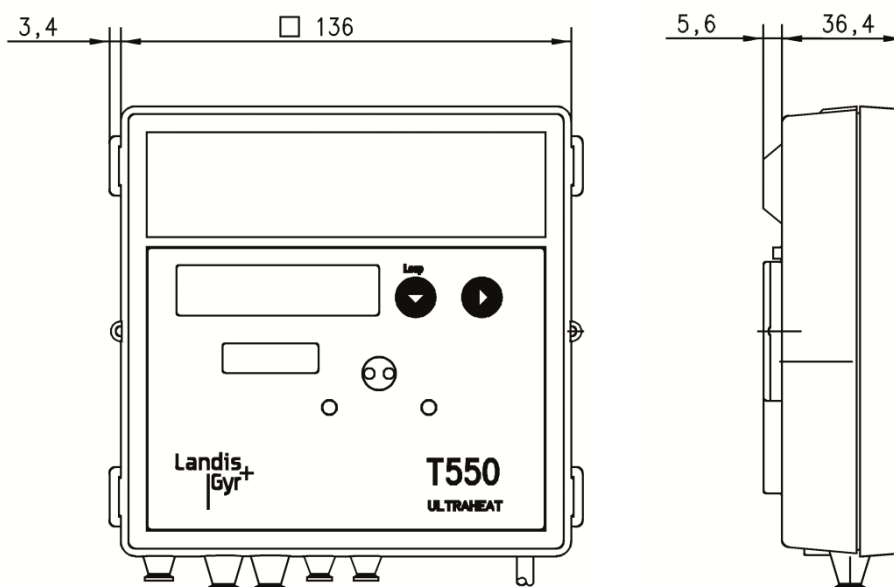

Fig. 5: Dimensions of electronic unit

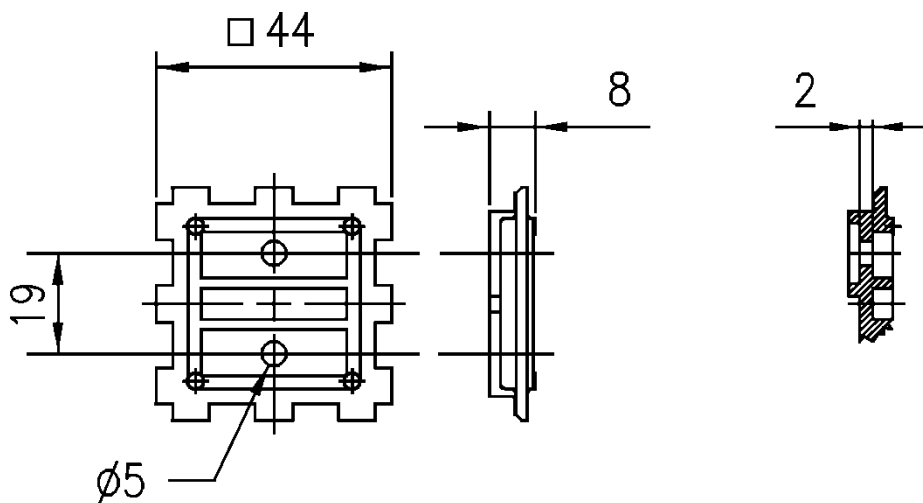

Fig. 6: Plan view and cross section of adapter plate

6 Operating elements

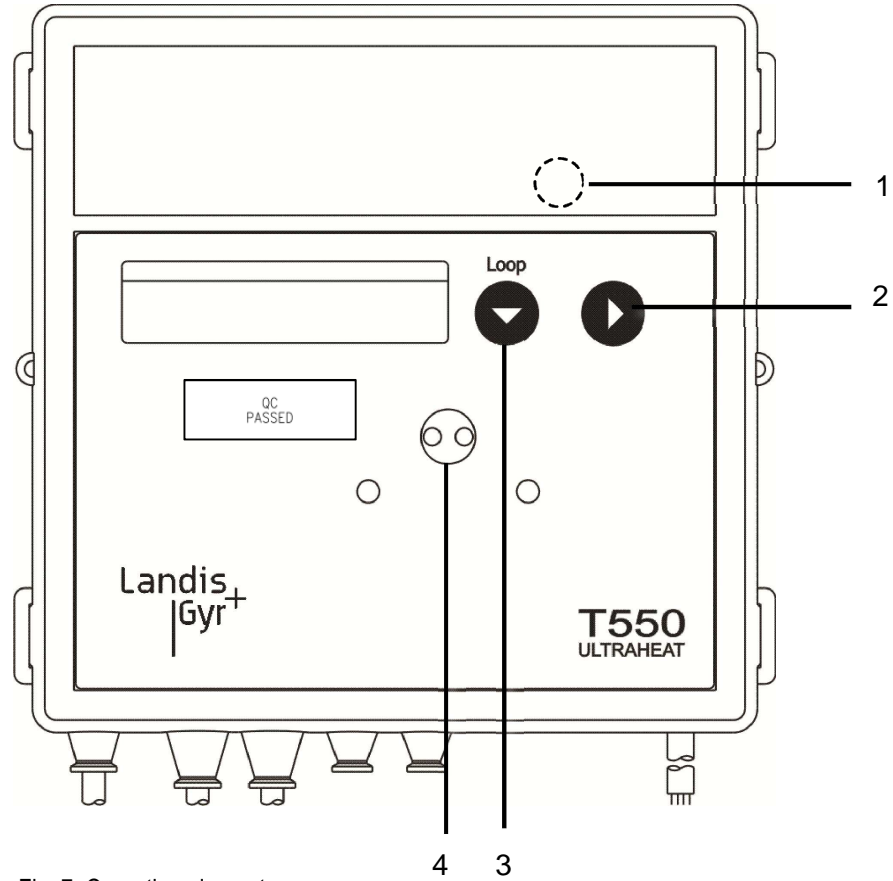

Fig. 7: Operating elements

Nr.	Name	Description	Note
1	Service button	To call up the parameterisation operation of the meter.	Accessible after removing the cover.
2	Button 2	Switches to the next display value within a loop.	
3	Button 1	Switches to the next loop.	
4	Optical interface	Permits data communication via a computer with the necessary service software.	

6.1 LCD

The calculator displays the current meter status in kWh, MWh, MJ or GJ.



Note: In order to prevent reading errors, the decimal places of the values displayed are marked with a frame.



Note: Calibrated values can be recognised by an additionally displayed star symbol.



Note: Both display range and data displayed can differ from the description depending on the appliance parameterisation. Certain button functions can also be blocked.

Display values “LOOPS”

LOOP 0	User loop
LOOP 1	Service loop 1
LOOP 2	Service loop 2
...	...
LOOP 0	User loop

After the last loop is displayed, the user loop “LOOP 0” comes up again.

User loop “LOOP 0”

The LCD shows the following values one after the other:

LOOP 0	Head of the loop
F - - - - -	In case of error: message with error code
.. 1234567 kWh	Energy accumulated with tariff status
T' 1234567 kWh	Tariff register 1,2,3 ¹⁾
1234567 m ³	Volume accumulated
PI 1-3	Volume pulse input 1 ²⁾
1234567 m ³	at 2-sec. cycles with current volume
PI 2-3	Volume pulse input 2 ²⁾
1234567 m ³	at 2-sec. cycles with current volume
☒☒888888☒☒/h	Segment test

Service loop 1 "LOOP 1"

Service loop 1 displays the details of the current measurement.

The LCD shows the following values one after the other:



LOOP 1	Head of the loop
1234 m ³ /h	Current flow
904 kW	Current power
TH 9,6 °C	Current temperature "hot", "cold" at 2-sec. cycles
TC 56,2 °C	
Δ 35,4 K	Temperature difference
V1 0065477	Volume pulse
VE 00000000 m ³	Volume at energy calculation
Od 1234 h	Operating time
Fd 123 h	Missing time
K 12345678	Property number, M-Bus secondary address
D 16,10,14	Date
Sd 3,05,--	Yearly set day (DD.MM)
1234567 kWh	Energy: previous year on set day at 2-sec. cycles with date
0,10,14	
T 1234567 kWh	Tariff register 1,2,3: previous year on set day ¹⁾
1234567 m ³	Volume: previous year on set day at 2-sec. cycles with date
0,10,14	
PI1-3	Volume pulse input 1 ²⁾ at 2-sec. cycles with volume previous year
1234567 m ³	
PI2-3	Volume pulse input 2 ²⁾ at 2-sec. cycles with volume previous year
1234567 m ³	
FW 8-07	Firmware version
CRC F177	CRC Code

Service loop 2 "LOOP 2"

Service loop 2 displays the installation details.

The LCD shows the following values one after the other:

LOOP 2	Head of the loop
PI000 1000 L/l	Pulse value
POS cold	Mounting place of the flow cold side or hot side
POS hot	

-  **Note:** At a **heat meter calculator** or combined heat / cold meter calculator the mounting place of the flow sensor cold side is equivalent to return. The mounting place of the flow sensor hot side is equivalent to flow.
-  **Note:** At a **cooling meter calculator** the mounting place of the flow sensor hot side is equivalent to the return. The mounting place of the flow sensor cold side is equivalent to flow.

Service loop 3 "LOOP 3"

Service loop 3 displays the monthly values.

- In order to display the monthly values, press button 2.
- The set day of the current month is displayed.
- To select the desired month, press button 1.

LOOP 3	Head of the loop
...	...
0 10 7,11 M	Set day for July 2011

- To request the associated values, press button 2.

The LCD displays the following values one after the other:

123456,7 kWh	Energy on set day
T 1234567 kWh	Tariff 1,2,3 on set day ¹⁾
1234567 m ³	Volume on set day
PI 1-3	Volume pulse input 1 ²⁾
1234567 m ³	at 2-sec. cycles with volume on set day
PI 2-3	Volume pulse input 2 ²⁾
1234567 m ³	at 2-sec. cycles with volume on set day
Ma 3,899 m ³ /h	Max. flow at period,
St 1306,11	at 2-sec. cycles with date stamp

M _a 2889 kW	Max. power at period, at 2-sec. cycles with date stamp
S _t 1306,11	
M _H 34,5 °C	Max. temperatures „warm“ at period, at 2-sec. cycles with date stamp
S _t 1306,11	
M _C 25,7 °C	Max. temperatures „cold“ at period, at 2-sec. cycles with date stamp
S _t 1306,11	
F _d 123 h	Missing time count on set day

After the last display the previously selected set day is displayed once again.

- To select the next set day, press button 1.

Service loop 4 “LOOP 4“

Service loop 4 displays appliance parameters.

The LCD displays the following values one after the other:

LOOP 4	Head of the loop
T ₂ 0,000 m ³ /h	Current tariff 1,2,3 ¹⁾
' 0,000 m ³ /h	in 2-sec. cycles with threshold value 1
Modul 1 M _B	Module 1: M-Bus module
FP1 127	M-Bus primary address 1
A 12345678	M-Bus secondary address 8-digit
Modul 2-1 C _E	Module 2: pulse module;
Modul 2-2 C _V	Channel 1 = energy, Channel 2 = volume;
PO1 125,00Wh/l	in 2-sec. cycles
PO2 0,0250 l/l	Value for energy pulses *)
PO3 2ms	Value for volume pulses *)
PI 1-1	Pulse duration in ms *)
0 1234567	Parameter pulse input 1 ²⁾
PI 1-2	in 2-sec. cycles with calculator number
2,50000 m/l	Parameter pulse input 2 ²⁾
	in 2-sec. cycles with pulse value

¹⁾ Visible if tariff is activated

²⁾ Visible if a module with pulse input is installed

*) for “fast pulses“

6.2 Previous year's values

The meter saves the following values on the yearly set day

- Energy (meter value)
 - Volume (meter value)
 - Tariff register (meter value)
 - Missing time (meter value)
- and the maxima with date stamp for
- Flow
 - Power
 - Temperature difference
 - Temperature hot side
 - Temperature cold side

6.3 Monthly values

The calculator saves the following values for 60 months on the monthly set day

- Energy (meter value)
 - Volume (meter value)
 - Tariff register (meter value)
 - Missing time (meter value)
- and the maxima with date stamp for
- Flow
 - Power
 - Temperature difference
 - Temperature hot side
 - Temperature cold side

The monthly values can be read via the optical interface.



Note: Central European Time (CET) applies as the standard time. During summer time the storage takes place at the corresponding times.

7 Parameterisation of pulse value and mounting place of flow sensor



Attention: Calculators with one-time adjustable pulse value and adaptable mounting place being characterized by:  .

The pulse value must be set in the para menu before the first use. The right mounting place of the flow sensor must be checked. As long as the pulse value hasn't yet been entered, the mounting place can be adapted.

PI000 1000 L/l

Pulse value

POS cold

Mounting place of the flow sensor (here: cold side)

Nb-----

Return to normal mode (manual)

Both entries will be adopted with the return in the normal operation and subsequently cannot be changed anymore!

LCD display will adopt automatically.

8 Display / priority rating

The view is limited to up to 7 entries. At pulse parameterization, the display will adapt automatically.

The display resolution can be selected from the following:

Pulse	Energy	Energy	Volume	Flow	Power
[l/p]	[MWh]	[GJ]	[m³]	[m³/h]	[kW]
1	0000.001	0000.001	00000.01	000.001	00000.1
2.5	0000.001	00000.01	00000.01	000.001	00000.1
10	00000.01	00000.01	000000.1	000.001	00000.1
25	00000.01	000000.1	000000.1	000.001	00000.1
100	000000.1	000000.1	0000001	0000.01	000001
250	000000.1	0000001	0000001	0000.01	000001
1.000	000000.1	0000001	0000001	0000.01	000001
2.500	000000.1	0000001	0000001	0000.01	000001



Note: Calculators up to 2.5 l/p can be parameterized to kWh. Calculators up to 1 l/p can be parameterized to MJ.

The pulse values are restricted by following connecting conditions:

Pulse	Max. power	Max. flow
[l/p]	[MW]	[m³/h]
1	3.3	24
2.5	3.3	24
10	33	240
25	33	240
100	330	2400
250	330	2400
1.000	330	2400
2.500	330	2400

9 Power supply

The calculator can be supplied with power via a battery supply modules as preferred. Battery and power supply are replaceable at any time.

Options:

- 6 years battery
- 11 years battery
- 16 years battery
- Power supply 230 V AC
- Power supply 110 V AC
- Power supply 24 V ACDC

Automatic power supply detection

The power supply detects whether a line voltage is applied. This signal is routed to the calculator. That enables the device to detect automatically whether it is being powered from a battery or power supply.

Power supply requirements

Requirements (for measuring timebase Q = 4 s and time base T = 30 s)	6 years	11 years	16 years	Power supply (230 / 110 V AC; 24 V ACDC)
Standard pulses, M-Bus read out (max. each 15 min.), CL-Module	2x AA	C	D	yes
M-Bus fast read out (max. each 4 sec.), fast pulses, analog module, radio module	D	--	--	yes
Fast measurement raster (for measuring timebase Q = 4 s and time base T = 4 s)	D	--	--	yes



Note: The lifetime of battery depends on the type of battery and on the requirements.



Note: Only batteries approved by the manufacturer may be installed.

Power supply modules

General

Pollution degree	per EN 61010 (no or only dry, non-conductive soiling)
Ambient temperature	5 ... 55 °C
Storage temperature	-20 ... 60 °C
Back-up time during power failure (power reserve)	> 20 minutes

24 V safety extra-low voltage

Voltage	12...36 V AC or 12...42 V DC
Frequency	50 / 60 Hz or DC
Galvanic isolation	1000 V DC
Power consumption	maximal 0.8 VA
Terminals for connecting cable	2 x 1.5 mm ² about, Ø 5.0...6.0 mm

110 V or 230 V alternating voltage

Voltage	85...121 V AC or 196...253 V AC
Type	Safety class II
Frequency	50 / 60 Hz
Line voltage fluctuations	max. 10 % of the nom. voltage
Oversvoltage category II per EN60010	2500 V impulse voltage
Power consumption	maximal 0.8 VA
Relative humidity	less than 93 % for T < 50°C
Cable length	1.5 / 5 / 10 m
Fuse protection	6 A MCB

10 Communication

Electronic unit interfaces

The calculator is equipped with an optical interface in accordance with EN 62056-21:2002 as standard.

You can additionally use the remote reading with up to 2 of the following communication modules:

- Pulse module
- M-Bus module G2
- M-Bus module G4
- M-Bus module G4 MI with 2 pulse inputs
- Analog module
- Radio module 433 MHz (for existing systems)
- Radio module 868 MHz
- GSM module
- GPRS module
- ZigBee module

These modules do not have an effect on the measurement. You can retrofit the modules at any time without damaging the security seal.



Note: You will find the technical details and data on communication modules in their respective documentation.

Permissible combinations of modules

		Step 1 Slot for module #2 is equipped with...												
		AM (5)	Pulse module		MB	MB G4	MB MI	CL	GPRS	GSM	RF 433 MHz	RF 868 MHz	ZB	
			"standard"	"fast" *)										
Step 2 Slot for module #1 can be equipped with...	AM	yes	yes	yes	yes (4)	yes	yes	yes	no	no	yes	yes	no	
	pulse module **) "standard"	yes	yes (3)	yes (2)	yes (4)	yes	yes	yes	yes	yes	yes	yes	yes	
	MB	yes	yes	yes	yes (4)	yes	yes	yes (1)	yes	yes	yes	yes	yes	
	MB G4	yes	yes	yes	yes	yes	yes	yes (1)	yes	yes	yes	yes	yes	
	MB MI	yes	yes	yes	yes	yes	yes	yes (1)	no	no	yes	yes	no	
	CL	yes	yes	yes	yes (1)	yes (1)	yes (1)	no	yes	yes	yes	yes	yes	

AM Analog module
 MB M-Bus module
 MB G4 M-Bus module
 MB MI M-Bus module
 CL CL module
 RF Radio module
 GPRS GPRS module
 ZB ZigBee module

Restrictions:

- *) only 1 module with fast pulses is possible; only permissible on slot 2; min. pulse duration:
 - 2 ms, if pulse module 1 not fitted
 - 5 ms, if pulse module 1 fitted
- **) Subsequent mounting of a further pulse module in module slot 1 can result in changed output values for module 2!
 - (1) For M-bus with fast read out, the CL read-out can take up to 40 s!
 - (2) Pulse length of the fast pulses min. 5 ms
 - (3) The first and second channel can be parameterized individually!
 - (4) The secondary address for both modules can only be changed via module No. 1!
 - (5) The analog module is not possible in module slot 2, when the calculator has a power supply module 110 V / 230 V!

Terminals

2-pole or 4-pole terminals are used for connection of the external cables to the modules.

- Outer diameter of the cable 4 ... 6 mm
- Connection capacity
 - rigid or flexible 0.2 ... 2.5 mm²
 - flexible with wire end ferrule 0.25 ... 1.5 mm²
 - conductor sizes 26 ... 14 AWG
- Multiple conductor connector (2 conductors with the same cross-section)
 - rigid or flexible, 0.2 ... 0.75 mm²
 - flexible with wire end ferrule without plastic sleeve, 0.25 ... 0.34 mm²
 - flexible with TWIN wire end ferrule with plastic sleeve, 0.5 ... 0.75 mm²
- Strip-back length 5 mm
- Recommended screwdriver:
 - 0.6 x 3.5 mm
- Tightening torque: 0.4 Nm

10.1 Pulse module

The pulse module permits the output of pulses that can be derived from the quantity of heat, the volume, tariff register 1, tariff register 2 or the mistake status. Two channels are available whose functions can be parameterized with the service software.

Output takes the form of standard pulses or “fast pulses”. The pulse duration is identical for channel 1 and channel 2.

Labelling	pulse module
Display in LCD	CE, C2, CV, CT or RI
Type	open collector
Voltage	max. 30 V
Current	max. 30 mA
Dielectric strength	500 V _{eff} against ground
Classification	OB (per EN 1434-2)
Voltage drop	approx. 1.3 V at 20 mA
Classification	OC (per EN 1434-2)
Voltage drop	approx. 0.3 V at 0.1 mA
Output connection (WZU-P2):	

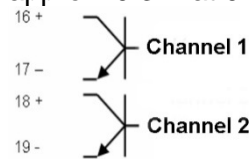

A special version WZU-P2L of the pulse module is available with an Opto-Mos output.

Advantages	low voltage drop and reverse polarity protected (bipolar)
Output connection (WZU-P2L):	

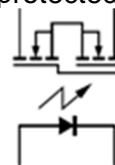

10.2 M-Bus module G4

The M-Bus module enables the meter to communicate with an M-Bus centre in order to transmit measured values.

Standard	EN 1434-3; EN 13757-2, -3
Protocol	EN 60870-5
Electrical isolation	
from calculator	yes
from the pulse inputs	no
Connection	
Strip-back length	5 mm
Connection capacity	
rigid or flexible	0.25 ... 0.75 mm ²
flexible with wire end ferrule	0.25 ... 0.75 mm ²
Polarity	any
Voltage	50 V DC maximal
Current consumption	1 M-Bus load (1.5 mA)
Addressing	primary or secondary
Baud rate	300, 1200, 2400, 4800 or 9600 baud
Interface description	see TKB3448

10.3 M-Bus module MI with 2 pulse inputs

The M-Bus module enables the meter to communicate with an M-Bus centre in order to transmit measured values. In addition to a possible voltage supply from the M-bus connection, the “MI” module is equipped with a battery. This powers the module processor and the pulse input, if no M-bus voltage is applied.

M-Bus	
Standard	EN 1434-3; EN 13757-2, -3
Protocol	EN 60870-5
Electrical isolation	
from calculator	yes
from the pulse inputs	no
Connection	
strip-back length	5 mm
Connection capacity	
rigid or flexible	0.25 ... 0.75 mm ²
flexible with wire end ferrule	0.25 ... 0.75 mm ²
Polarity	any
Voltage	50 V DC max.
Current consumption	1 M-Bus load (1.5 mA)
Addressing	primary or secondary
Baud rate	300, 1200, 2400, 4800 or 9600 baud
Interface description	see TKB3448
Pulse input	
Number of pulse inputs	2 pulse inputs per “MI” module
Life of the module battery	5 years of operation + 1 year storage duration; if the M-bus voltage is applied for at least 90% of the operating time, the battery life increased to 10 years
Standard for pulse inputs	Class IB per EN 1434-2
Frequency	max. 10 Hz
Pulse duration (low)	≥ 50 ms

No-pulse duration (high)	≥ 50 ms
Pulse value	0.01 litres/pulse, in steps of 10 000.00 litres/pulse, in steps of 0.01 litres/pulse
Display and output	in m ³ , 7-digit; acc. to parameter setting with or without 1 decimal place
Polarity	yes, must be correct, if transmitter is of type "open collector"
Electrical isolation	
from calculator	yes
from the M-bus inputs	no
Output voltage	approx. 3.3 V
Internal resistance	approx. 1 MΩ
Source current	approx. 3 μA
Pulse input closed (low)	Switching threshold low < 0.2 V Resistance < 50 kΩ
Pulse input open (high)	Switching threshold high: unconnected collector Resistance ≥ 6 MΩ
Connection	Strip-back length 5 mm
Connection capacity	
rigid or flexible	0.25 ... 0.75 mm ²
flexible with wire end ferrule	0.25 ... 0.75 mm ²
Permissible cable length	max. 10 m

10.4 Analog module

The analog module converts the measured value from the meter to an analog signal.

Power supply range	12 ... 30 V AC 12 ... 42 V AC
Power supply protection	
< 24V	200 mA, slow blow
≥ 24V	100 mA, slow blow
Max. current consumption	170 mA @ 12 Volt
Power consumption	max. 2 Watt
Max. output load	300 Ohm for current output, 2 kOhm for voltage output (outputs are short circuit proof)
Accuracy	≤ ±1% of parameterized max. value
Max. length of connections	100 m
Outer diameter of connections	up to 1.5 mm ²

10.5 Radio module 868 MHz (wireless M-Bus)

The radio module 868 MHz enables the calculator to communicate with a centre (receiver) using 868 MHz radio frequency. The radio module 868 MHz supports as well OMS¹⁾ as DSMR²⁾ compliant data transfer.

A data transmission to an OMS radio concentrator (Smart Meter Gateway) or the L+G mobile radio readout system Q4 is possible.

Frequency	868.95 MHz (868.90 MHz up to 869.00 MHz)
Transmission power (ERP)	min. 3.16 mW (5 dBm) up to max. 25 mW (13.9 dBm)
Receive frequency	868.30 MHz (868.00 MHz up to 869.60 MHz)
Range*)	
free field	up to 400 m
inside buildings	e.g. horizontally 30 m
Power supply	
via calculator **)	Battery type D
via power supply	110 / 230 / 24 V
Standard	EN13757-2/ -4

¹⁾ Open Metering System

²⁾ Dutch Smart Metering Requirements

*) Depending on the structure of the building can deviate significantly

**) Battery power supply depends on the kind of the data output. This must especially be taken into account when upgrading an existing meter. If the battery of the meter is of any other type, it must be replaced by a battery of type D 11-years. Meters that are supplied with a radio module from the factory are already equipped with the correct battery.

10.6 GSM module

The GSM module is intended for wireless data transmission (remote readout) in the form of SMS messages based on the GSM network^{*)}. In addition, a period for automatic logon or data transmission can be configured between 6 minutes and 45 days.

The module is programmed by configuration SMS messages.

GSM

Frequency (transmission power)	900 MHz (max. 2 W), 1800 and 1900 MHz (max. 1 W)
Coverage	according to availability of GSM network
Supply	3.6 V lithium battery, block of 2 AA cells, independent of heat meter
Battery life	up to approx. 1600 SMS or 6 years (depends on GSM signal strength at the installation point)

Pulse input

Number of pulse inputs	2 pulse inputs
Standard for pulse inputs	Class IB per EN 1434-2
Frequency	max. 10 Hz
Pulse duration (low)	≥ 50 ms
No-pulse duration (high)	≥ 50 ms
Pulse value	0.01 litres/pulse, in steps of 10 000.00 litres/pulse, in steps of 0.01 litres/pulse
Electrical isolation	yes
Output voltage	pulse inputs I1 and I2 with common grounding
Internal resistance	approx. 3.3 V
Source current	approx. 1.5 MΩ
Pulse input closed (low)	approx. 2 μA
Switching threshold low	< 0,2 V
Resistance	< 50 kΩ
Pulse input open (high)	
Switching threshold high	unconnected collector
Resistance	≥ 6 MΩ
Connection	Strip-back length 5 mm
Connection capacity	rigid or flexible, 0.25 ... 0.75 mm ² ; flexible with wire end ferrule, 0.25 ... 0.75 mm ²
Permissible cable length	max. 10 m

^{*)} SIM card is required

10.7 GPRS module

The GPRS module is used for data acquisition over a mobile network^{*)}, using open standard protocols^{**)} in push mode (as Email, HTTP, FTP, SMS) or pull mode as transparent M-Bus (GSM, TCP). The integration into billing systems happens via selectable report templates.

The module is configured by SMS messages. A firmware update is possible at any time ("Over the Air").

The module includes an integrated M-Bus Master, which allows to read out up to 8 additional M-Bus Meter (so-called slaves). The meter data can be stored and send at configurable intervals. In addition, "ad hoc" readings are possible.

Connection M-Bus	Screw terminal 0.25 to 1.5 mm ²
Power supply	via power supply (calculator)
Nominal voltage	100 - 240 V AC
Voltage range	-20 % to +15 % of nominal voltage
Frequency	50/60 Hz
Power consumption (Max)	< 2.5 VA
Power consumption (Nom)	< 1 VA
Installation / overvoltage	CAT 2
GPRS Class	12
Band	850 / 9000 / 1800 / 1900 MHz
Operating temperature range	-30 to +55°C
Storage temperature range	-40 to +85°C
Operating humidity max.	80 % RH
Pollution	Grade 2
Operating altitude	0 - 2000 m
Indoor use only	Yes
LED Indication	green, yellow, red
M-Bus standard	13757
M-Bus baud rate	300 and 2400 Bit/s
Transparent M-Bus	Listening server on TCP and GSM data
Maximum connected M-Bus slaves	8
Maximum cable length	1000 m
Real Time Clock Backup	3 days
Real Time Clock Accuracy	< 2 sec / day
Data storage (Data logger function)	1.3 MByte

^{*)} SIM card is required

^{**)} Communication protocols

- E-Mail using SMTP with authentication mode HELO, EHLO
- FTP passive mode with authentication and remote directory change
- HTTP POST and GET
- GSM data Transparent M-Bus @ 300 and 2400 baud and GSM data console
- TCP Transparent M-Bus @ 300 and 2400 baud and TCP console
- SMS for configuration
- Internet time synchronization using NTP or Daytime protocol

10.8 ZigBee module

Das ZigBee module enables the meter to communicate with a ZigBee Smart Energy Coordinator/Gateway with Trust Centre in order to transmit measured values.

Standard Protocol	IEE 802.15.4 ZigBee Pro Smart Energy (SE) 1.1 End Point Device
Frequency	2.4 GHz 16 5MHz channels
Chipset	Ember EM 357
Standby current	1 μ A type
Rx/Tx current	25 mA / 31 mA type
Rx sensitivity (typ.)	up to -101 dBm
Tx power (typ.)	up to +8 dBm
Interface description	TKB 3466

11 Tariff control (optional)



Note: The tariffs can only be parameterized using the service software.



Note: The summation of quantity of energy and volume in the standard registers is performed independently of the tariff situation.

The following options are available for tariff control:

Threshold value tariff (Tariffs T2, T3, T4, T5, T6)

The threshold value tariff can be derived from

- the flowrate (tariff T2),
- the power (tariff T3),
- the temperature cold side (tariff T4),
- the temperature warm side (tariff T5) or
- the temperature difference (tariff T6).

The total heat quantity and the total volume are always summed. But the heat quantity or the volume can also be acquired dependently from threshold value in up to 3 tariff register.

Jedes Tarifregister wird über eine Tarifschwelle gesteuert.

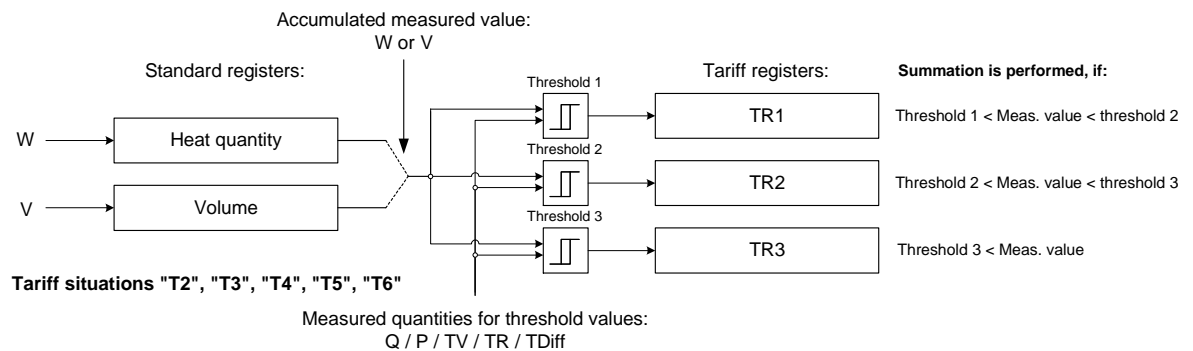

Fig. 8

Summation in the relevant tariff register is only performed if the relevant threshold is exceeded.

- Threshold 1 exceeded: Summation in tariff register 1
- Thresholds 1 and 2 exceeded: Summation in tariff register 2
- Thresholds 1, 2 and 3 exceeded: Summation in tariff register 3

Supplied quantity of energy (tariff T7)

In tariff register 1, a quantity of energy is summated that is calculated from the temperature warm side (instead of from the temperature difference).

Returned quantity of energy (tariff T8)

In tariff register 1, a quantity of energy is summated that is calculated from the temperature cold side (instead of from the temperature difference).

Heat / cooling meter (tariff T9)

In tariff register 1, the measured quantity of cold; in tariff register 2, the measured quantity of heat is summated. In both cases a threshold can be defined via the temperature hot side (“cold threshold”, “heat threshold”).

- Temperature above “heat threshold” and temperature difference $> +0.2$ K → quantity of heat is acquired
- Temperature below “cold threshold” and temperature difference < -0.2 K → quantity of cold is acquired

Tariff control via timer switch (tariff T10)

For tariff control, one switch-off time and one switch-on time per day can be defined. At the switch-on time, summation of the quantity of energy or volume is started in tariff register 1; at the switch-off time, it is ended.

Tariff control via M-Bus (tariff T11)

In tariff registers 1, 2 and 3, either the quantity of energy or the volume can be summated. With the relevant M-bus command, one of the 3 tariffs can be activated or all tariffs can be deactivated.

Surcharge quantity tariff by means of return temperature (tariff T12)

The quantity of energy is summated depending on the temperature cold side in tariff registers 1 or 2.

The summated quantity of energy is calculated from the difference of the temperature cold side from the defined return temperature threshold (instead of from the temperature difference).

- Above return threshold: T1 is summated
- Below return threshold: T2 is summated

Display of the tariff situation on the LCD

The current tariff status is shown in the user loop “LOOP 0” together with the quantity of energy or the volume.

No tariff status is shown for tariffs T7 and T8.

For tariffs T2, T3, T4, T5, T6, T10, T11 and T12

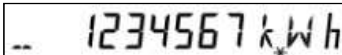
 no tariff register active

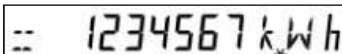
 tariff register 1 active

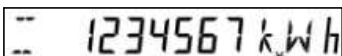
 tariff register 2 active

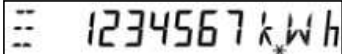
 tariff register 3 active

For tariffs T9 (heating/cooling meter)

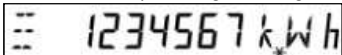
 no tariff register active

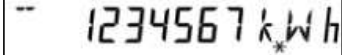
 tariff register 1 active

 tariff register 2 active

The type of tariff and the associated parameters are displayed in service loop “LOOP 4”.

T2 0,000 m/h	for T2, T3, T4, T5, T6 in 2-sec. cycles with threshold value 1/2/3
' 0,000 m/h	
T7 0 °C	for T7
T8 0 °C	for T8
T9c 18 °C	for T9;
T9h 45 °C	in 2sec. cycles
T 10 -----	
01 00,00 0	for T10; switching times in 2-sec. cycles
02 12,00 1	
T 11 -----	for T11
T 12 50 °C	for T12

The contents of the tariff registers are displayed in the user loop after the quantity of energy.

For tariffs T2, T3, T4, T5, T6, T10, T11 and T12

T' 1234567 kWh	tariff register 1
T'' 1234567 kWh	tariff register 2
T''' 1234567 kWh	tariff register 3 (not for T12)
TH 1234567 kWh	for tariff T7
RH 1234567 kWh	for tariff T8
HE 1234567 kWh	for tariff T9
C 1234567 kWh	

12 Error messages

The calculator continuously runs a self-diagnosis and can thus recognise and display various installation or meter error messages.

Error code	Error	Service guidelines
DIFF nEG	Negative temperature difference	Check installation point of the temperature sensors; exchange if necessary
if necessary in exchange with:		
F1	Interruption in the hot side temperature sensor	Check hot side temperature sensors; replace if necessary
F2	Interruption in the cold side temperature sensor	Check cold side temperature sensors; replace if necessary
F3	Electronics for temperature evaluation defective	Exchange the calculator
F4	Problem with the power supply; Battery flat;	Check connection; Change battery
F5	Short-circuit hot side temperature sensor	Check hot side temperature sensors; replace if necessary
F6	Short-circuit cold side temperature sensor	Check cold side temperature sensors; replace if necessary
F7	Fault in internal memory holding	Exchange the calculator
F9	Fault in the electronics	Exchange the calculator



Note: All error messages are deleted automatically once the error has been rectified.

13 Log functions

In the internal logbook, metrologically relevant events (errors, states, actions) are stored in chronological order with their time of occurrence. The events acquired are predefined. The data of the logbook cannot be deleted.

Each event is stored in a separate 4-level shift register; the overflows are transferred to a 25-level circulating buffer. Therefore, at least the last 4 times can be traced for each event.

In a monthly register, the error states are stored for the current month and for the past 18 months (without time stamp).

Ser. Nr.	Description
2	F1 = Interruption temperature sensor hot side
3	F2 = Interruption temperature sensor cold side
4	F3 = Error temperature electronics
5	F5 = Short-circuit temperature sensor hot side
6	F6 = Short-circuit temperature sensor cold side
8	F9 = ASIC error
13	Line voltage off
14	CRC error occurred
15	Adjustment values parameterized
16	F7-(EEPROM) pre-warning
17	Reset made
18	Date / time parameterized
19	Yearly set day parameterized
20	Monthly set das parameterised
21	Master reset performed
22	All times deleted
23	Missing time deleted
24	Maxima deleted



Note: Read-out is performed via the optical interface with the service software.

14 Data logger (optional)

The data logger permits the archiving of data that the user can select from a predefined set of values. The data logger contains four archives whose 8 channels can be assigned. The data can be assigned to any of the channels.

Archive	Timebase	Storage depth	Averaging time for maximum*)
Hourly archive	1 hour	45 days	1 hour
Daily archive	1 day	65 days	1 hour
Monthly archive	1 month	15 months	1 hour
Yearly archive	1 year	15 years	1 hour / 24 hours

*) For a shorter measuring period than 1 hour, the largest value from the maximum values calculated within one hour applies.



Note: Parameterisation and read-out are performed with the service software.



Note: Data transmission is in a manufacturer-specific format.

	Value set for data to be recorded
Meter readings at the end of the period for...	Quantity of energy Tariff register 1, 2, 3 Volume Operating duration*) Fault duration*) Pulse input 1 Pulse input 2
Instantaneous values at the end of the period for...	Power Flowrate Temperature hot side Temperature cold side Temperature difference Error display
Maximum for...	Power Flowrate Temperature hot side Temperature cold side Temperature difference

*) depending on parameter setting: hours or days

15 Additional options

Options:

- Version with data logger
 - Available for order as cooling meter calculator with German national approval
 - Combined heat / cooling meter calculator
 - Available for order for liquid mixtures (e. g. glycol / water)
 - Available for order with one-time adjustable pulse value and mounting place of the flow sensor
-

16 Order codes (type number key)

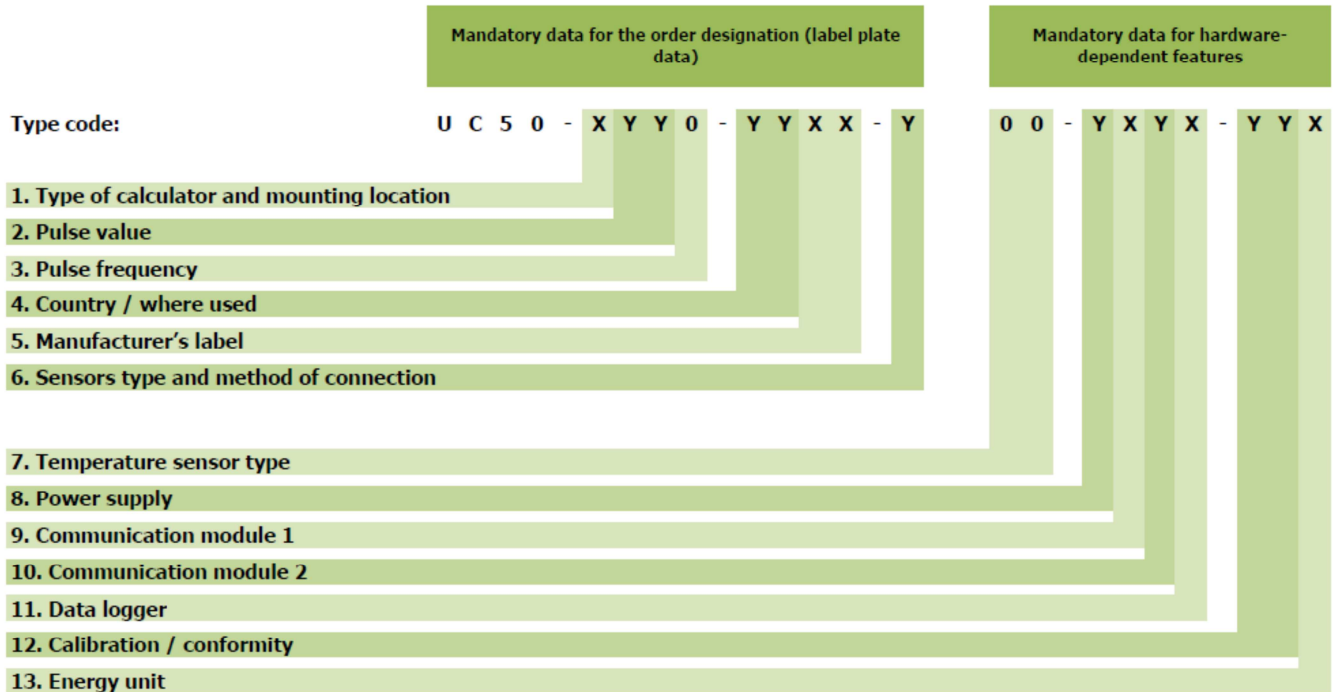

Order codes for label plate data	
1. Type of calculator and mounting location	Code
Flow sensor	D
Calculator for heat measurement, four-wire technology, mounting place of flow sensor cold side (flow)	L
Calculator for heat measurement, four-wire technology, mounting place of flow sensor hot side (flow)	M
Calculator (combined) heat/cooling measurement, four-wire technology, mounting place of flow sensor cold side (return), only in combination with temperature sensors Pt 500	N
Calculator cooling measurement, four-wire technology, mounting place of flow sensor hot side (return)	T
Calculator for cooling measurement, four-wire technology, mounting place of flow sensor cold side (flow)	U
Calculator for heat measurement, medium glycol, four-wire technology, mounting place of flow sensor cold side (return) ¹⁾	5
Calculator for heat measurement, medium glycol, four-wire technology, mounting place of flow sensor hot side (flow) ¹⁾	6
Calculator for cooling measurement, medium glycol, four-wire technology, mounting place of flow sensor hot side (return) ¹⁾	7
Calculator for cooling measurement, medium glycol, four-wire technology, mounting place of flow sensor cold side (flow) ¹⁾	8
Calculator (combined) for heat/cooling measurement, medium glycol, four-wire technology, mounting place of flow sensor cold side (return) ¹⁾	9
2. Pulse value	Code
One-time adjustable pulse value	00
Pulse value 1 l/pulse	01
Pulse value 2.5 l/pulse	02
Pulse value 10 l/pulse	03
Pulse value 25 l/pulse	04
Pulse value 100 l/pulse	05
Pulse value 250 l/pulse	06

Pulse value 1000 l/pulse	07
Pulse value 2500 l/pulse	08
3. Pulse frequency	Code
Maximal pulse frequency 50 Hz	0
4. Country / where used	Code
Dial plate for Middle East (English)	AE
Dial plate for Austria (German)	AT
Dial plate for Switzerland (German/French)	CH
Dial plate for China (Chinese)	CN
Dial plate for Czech Republic (Czech)	CZ
Dial plate for Germany (German)	DE
Dial plate English neutral	EN
Dial plate for Great Britain (English)	GB
Dial plate for The Netherlands (Dutch)	NL
Dial plate for Norway (Norwegian)	NO
Dial plate for Poland (Polish)	PL
Dial plate for Sweden (Swedish)	SE
Dial plate for Slovak Republic (Slovakian)	SK
5. Manufacturer's label	Code
Logo Landis+Gyr	00
Other labels on request	xx
6. Sensors type and method of connection	Code
Flow sensor (without temperature sensors)	0
Sensor Pt100, removable	A
Sensor Pt500, removable	E
Hardware dependent features	
7. Temperature sensor type	Code
Without temperature sensors	00
8. Power supply	Code
Without power supply	0
Standard battery for 6 years (2xAA cells)	A
Battery for 6 years for all applications (D cells)	B
Battery for 11 years (C cells)	C
Battery for 11 years (D cells)	E
Battery for 16 years (D cells)	F

Power supply 24V AC/DC with plugs	M
Power supply 230V AC with 1.5 m cable	N
Power supply 230V AC with 5 m cable	P
Power supply 230V AC with 10 m cable	Q
Power supply 110V AC with 1,5 m cable	R
Power supply 110V AC with 5 m cable	S
Power supply 110V AC with 10 m cable	T
Power supply 230V AC with 3 m cable for high current application	V
Power supply 24V AC/DC with plugs for high current application	W
9. Communication module in slot 1	Code
No module in slot 1	0
Analog module	A
M-Bus module	B
M-Bus module 30s	D
M-Bus module G4	M
M-Bus module G4-MI with 2 pulse inputs	N
Pulse module with OptoMOS	L
Pulse module standard	P
10. Communication module in slot 2	Code
No module in slot 2	0
Analog module	A
M-Bus module G4	B
M-Bus module 30 s	D
Radio module 868 MHz *)	E
Radio module 868 MHz with external antenna *)	F
GPRS module	H
GPRS module (incl. SIM card)	J
Pulse module with OptoMOS	L
M-Bus module G4	M
Pulse module standard	P
ZigBee module	S
Radio module 433 MHz	R
Radio module 433 MHz with external antenna	X
11. Data logger	Code
Without data logger	0
Data logger with 8 channels	8
12. Calibration / conformity	Code
Compliant acc. to national regulations	CL

Compliant to MID, class 2	M2
Compliant with CEN 1434, class 2	T2
Compliant acc. to national regulations	TL
13. Energy unit	Code
Display: kWh (until qp 10)	A
Display: MWh with 3 decimal places (as of qp 15 with 2 decimal places)	B
Display: MJ (until qp 2.5)	C
Display: GJ with 3 decimal places (as of qp 3.5 with 2 decimal places; as of qp 40 with 1 decimal place)	D
Only for flow sensor:	
Display: m ³ with 2 decimal places (as of qp 25 with 1 decimal place)	V

*) Additional ordering information needed (see page 38)

¹) Additional ordering information needed (see page 39)

Note

The following applies for MID conforming appliances in Germany: For new installations in pipework less than or equal to DN 25, the installation of short sensors must only be made if they are directly immersed.

Landis+Gyr GmbH
Humboldtstrasse 64
90459 Nuremberg
Germany

17 Additional ordering information on radio module 868 MHz (wireless M-Bus)

Necessary additional ordering information:

For OMS:

1. Protocol type
2. Sending interval
3. Encryption
4. Data telegram

For DSMR:

1. Protocol type
 - Depending on the recipient (receiver)
 - Receiver is L+G E350 + int. radio module (XEMEX): "Radio DSMR compliant" with encrypted time set
 - Receiver is L+G E350 + Dongle (V 2.51 / V 4.0): "Radio DSMR-similar, for pre-binding on dongle" with encrypted time set
 - Receiver is L+G E350 + int. Radio module (XEMEX): "Radio DSMR compliant" with unencrypted time set
 - Receiver is L+G E350 + Dongle (V 2.51 / V 4.0): "Radio DSMR-similar, for pre-binding on dongle" with unencrypted time set
2. Sending interval
 - For DSMR always 60 minutes (code 7)

Description	OMS Code	DSMR Code
1. Protocol type	Code	Code
Radio DSMR compliant with encrypted time set		0
Radio DSMR similar for pre-binding on dongle with encrypted time set		1
OMS / wireless M-Bus	2	
Radio DSMR compliant with unencrypted time set		4
Radio DSMR similar for pre-binding on dongle with unencrypted time set		5
2. Sending interval	Code	Code
Sending interval of 15 minutes	0	
Sending interval of 30 seconds	2	
Sending interval of 1 minutes	3	
Sending interval of 5 minutes	4	
Sending interval of 12 hours	6	
Sending interval of 60 minutes	7	7
Sending interval of 20 seconds	8	
Sending interval of 12 seconds	9	
3. Encryption	Code	Code
None	0	
AES-128 Bit	1	

4. Data telegram	Code	Code
Telegram radio standard	P600	
Telegram mobile radio	P601	
Telegram mobile radio with tariffs	P602	

More data telegrams for OMS on request.

Ordering examples:

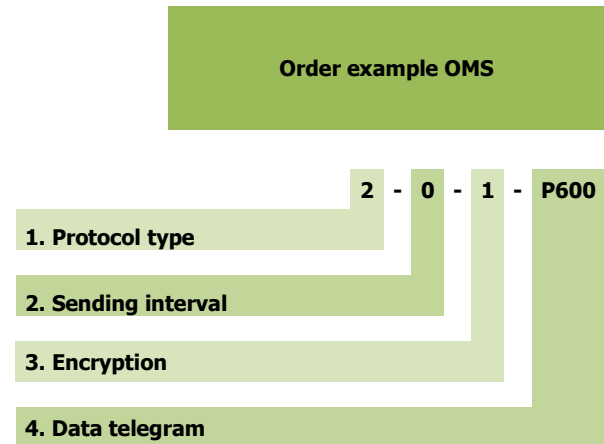

UC50-XXX0-Y 00-YXEX-YYX + **2-0-1-P600**

- E = Radio module 868 MHz (wireless M-Bus)
- 2 = OMS/wireless M-Bus
- 0 = Sending interval of 30 seconds
- 1 = AES-128 Bit
- P600 = Telegram radio standard

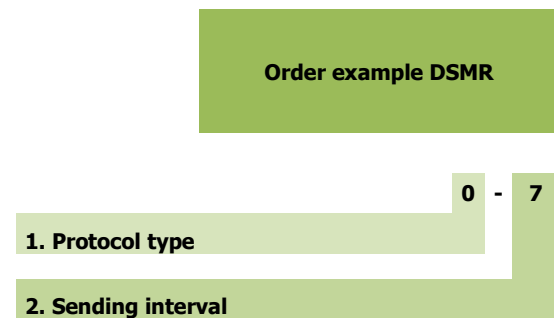

UC50-XXX0-Y 00-YXEX-YYX + **0-7**

- E = Radio module 868 MHz (wireless M-Bus)
- 0 = Radio DSMR compliant with encrypted time set
- 7 = Sending interval of 60 minutes

18 Additional ordering information for glycol

T550 (UC50...) can be used as a calculator (acc. EN1434, not calibrated) for determination of heat / cold flow volume of liquid mixtures (e.g. glycol/water). An adjustment can be performed with the service software.

Available medium	Order code: ME_UC50_GLY =	Continuation:	
Tyfocor ® LS	= 01	Glythermin P 44 ® 50%	= 23
Tyfocor ® 30%	= 02	Ethylene Glycol 30%	= 24
Tyfocor ® 40%	= 03	Ethylene Glycol 40%	= 25
Tyfocor ® 50%	= 04	Ethylene Glycol 50%	= 26
Tyfocor L ® 30%	= 05	1.2 Propylene Glykol 30%	= 27
Tyfocor L ® 40%	= 06	1.2 Propylene Glykol 40%	= 28
Tyfocor L ® 50%	= 07	1.2 Propylene Glykol 50%	= 29
Antifrogen N ® 30%	= 08	Fernox HP-5c 20%	= 31
Antifrogen N ® 40%	= 09	Fernox HP-5c 30%	= 32
Antifrogen N ® 50%	= 10	Antifrogen N ® 20%	= 33
Antifrogen L ® 30%	= 11	1.2 Propylene Glykol 20%	= 34
Antifrogen L ® 40%	= 12	Dowcal 100 ® 30%	= 35
Antifrogen L ® 50%	= 13	Dowcal 100 ® 40%	= 36
Antifrogen SOL ®	= 14	Dowcal 100 ® 50%	= 37
Dowcal 10 ® 30%	= 15	Ethanol 20%	= 38
Dowcal 10 ® 40%	= 16	Ethanol 30%	= 39
Dowcal 10 ® 50%	= 17	Ethanol 40%	= 40
Dowcal 20 ® 30%	= 18	Ethanol 50%	= 41
Dowcal 20 ® 40%	= 19	Dowcal 100 ® 35%	= 42
Dowcal 20 ® 50%	= 20	Ethylene Glycol 25%	= 43
Glythermin P 44 ® 30%	= 21	Ethylene Glycol 20%	= 44
Glythermin P 44 ® 40%	= 22		



Example for ordering:

UC50-**5**YY0-Y 00-YXYX-T2X + **ME_UC50_GLY = 01**

5 = Calculator for heat measurement (medium glycol) for mounting place of flow sensor cold side (return)

01 = Tyfocor ® LS